

**5.2.4. Snap joint**

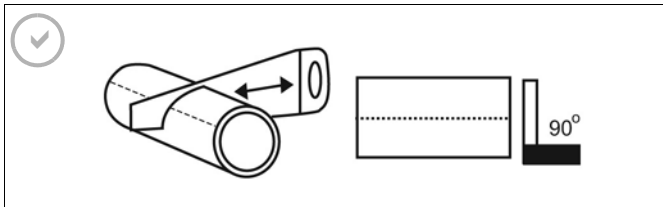
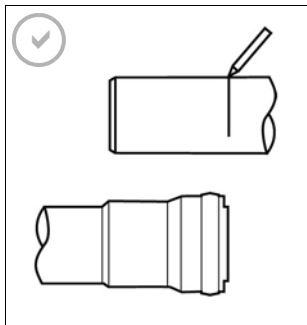

For making pull-tight connections, snap(expansion) sockets are available. These sockets are plug-in sockets with an extra snap ring which provides, in combination with a groove in the pipe, a pull-tight connection.

*Joining process:*

**Cut pipe square and remove burr**

**Mark insertion depth**

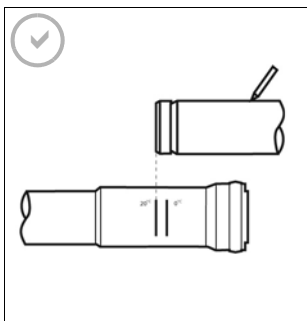
***Snap socket:***

The pipe needs to be inserted in the snap-socket using the full insertion depth.

A snap socket is not to be used to accommodate the expansion and contraction of a pipe system.

***Snap-expansion socket:***

A snap-expansion socket is used to accommodate the expansion and contraction in a pipe system.

The insertion depth is marked on the socket for both ambient temperatures of 0° and 20°C. For detailed information see also chapter 6.2.